

O. J. BOLLINGER.
Millstone Supporting and Driving Devices.
No. 221,906. Patented Nov. 25, 1879.

Fig. 1.

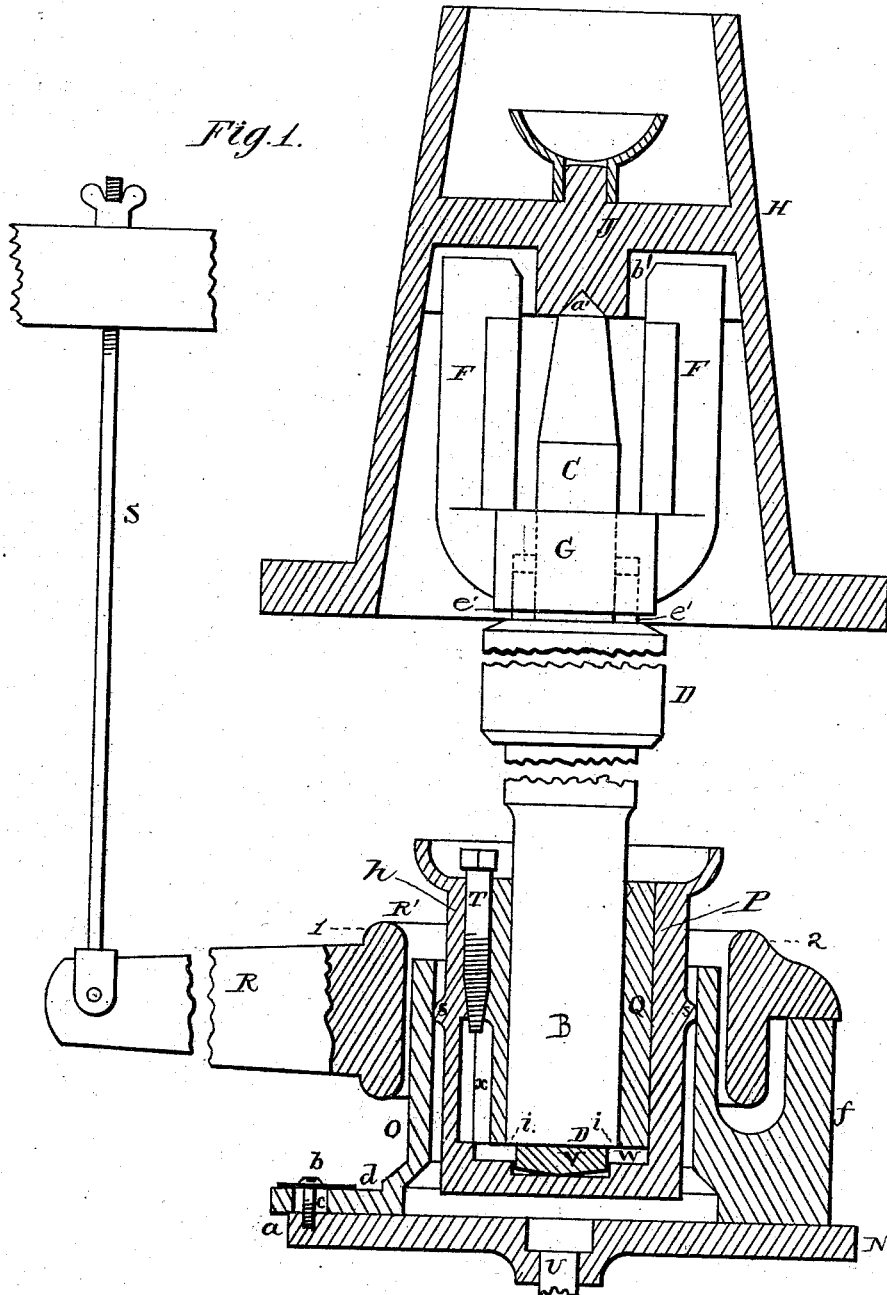

Attest:
Courtney A. Cooper
William Paxton

Inventor
O. J. Bollinger
By his attorney
Charles E. Foster

O. J. BOLLINGER.
 Millstone Supporting and Driving Devices.
 No. 221,906. Patented Nov. 25, 1879.

Fig. 2.

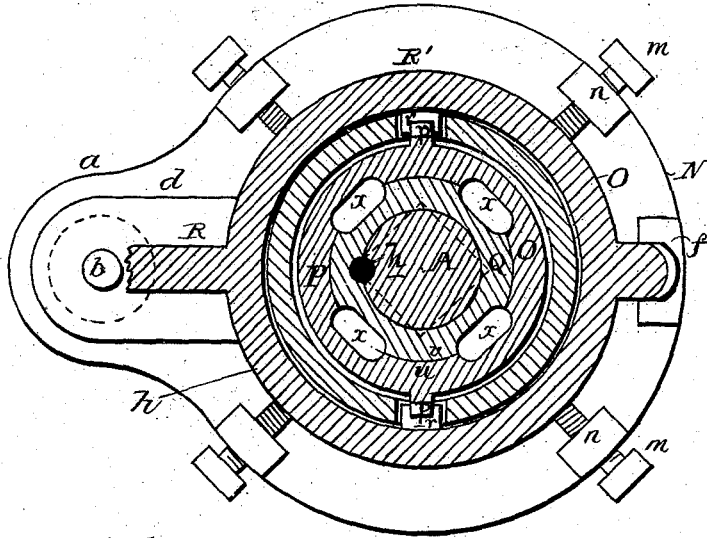

Fig. 3.

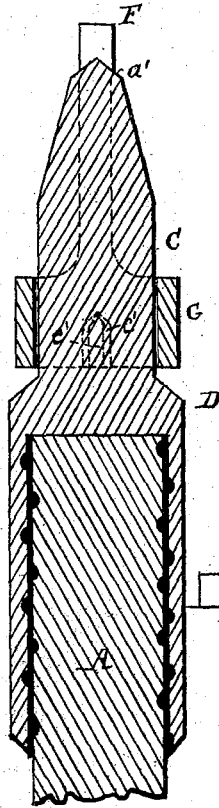
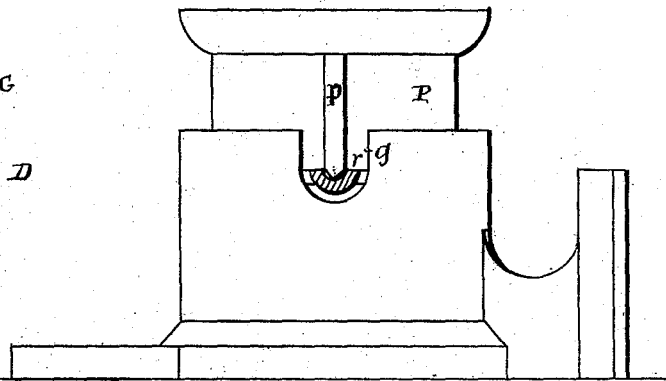

Fig. 4.



Attest:
 Courtney A. Cooper.
 William Paxton.

Inventor:
 O. J. Bollinger
 By his attorney
 Charles E. Foster

O. J. BOLLINGER.
Millstone Supporting and Driving Devices.
No. 221,906. Patented Nov. 25, 1879.

Fig. 6.

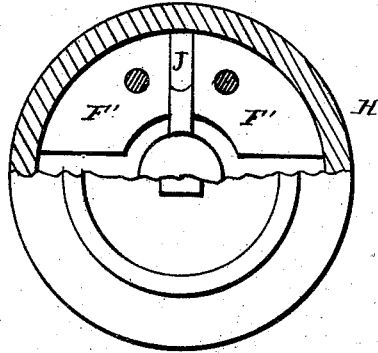
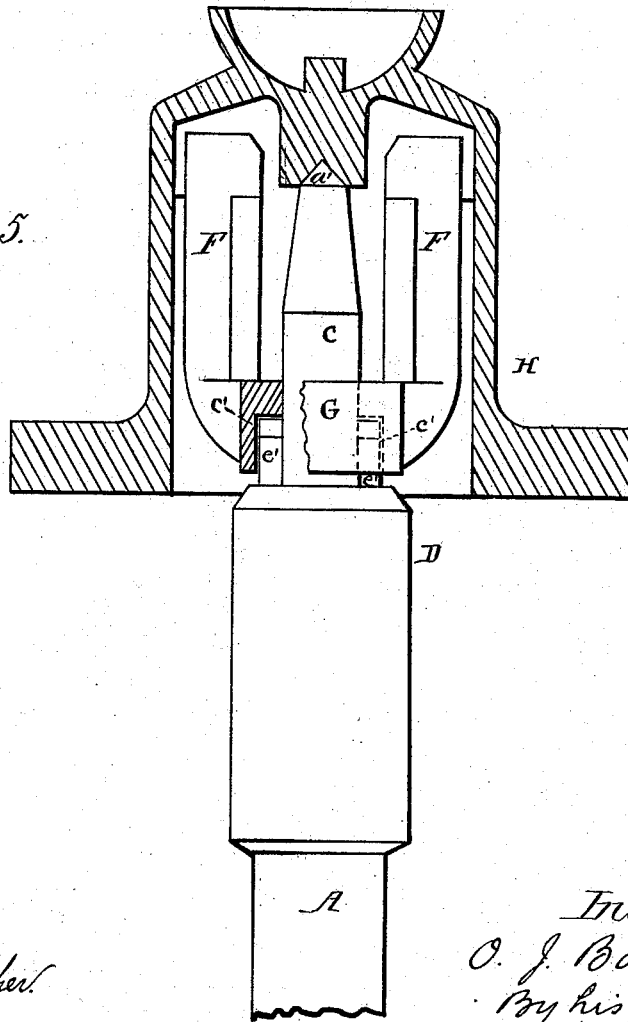

Fig. 5.



Attest:
Courtney A. Cooper.
William Paxton.

Inventor:
O. J. Bollinger
By his attorney
Charles E. Foster

UNITED STATES PATENT OFFICE.

OLIVER J. BOLLINGER, OF YORK, PENNSYLVANIA.

IMPROVEMENT IN MILLSTONE SUPPORTING AND DRIVING DEVICES.

Specification forming part of Letters Patent No. **221,906**, dated November 25, 1879; application filed February 20, 1879.

To all whom it may concern:

Be it known that I, OLIVER J. BOLLINGER, of York, York county, Pennsylvania, have invented Improvements in Devices for Supporting and Driving Millstones, of which the following is the specification.

My invention relates to devices for hanging, supporting, and driving a millstone, constructed as fully described hereinafter, to secure hard and durable bearings, reduce friction, prevent unequal wear and backlash, and permit nice and easy adjustment.

In the drawings, forming part of this specification, Figure 1 is a sectional elevation illustrating my invention; Fig. 2, a sectional plan of the line 1 2, Fig. 1; Fig. 3, a section of the shaft, end piece, and driver; Fig. 4, a detached view of part of the step; Fig. 5, a section showing a modification; and Fig. 6, a plan, in part section, of Fig. 5.

A is the spindle; B, the step; F G, the driver; and H the cone-bail. The step consists of a base-plate, N, secured by a central bolt, U, and having a tongue, *a*, at one side. A central cylindrical case, O, rests upon this base, and is secured thereto by a bolt, *b*, extending through a slot, *c*, in a lateral tongue, *d*, into the tongue *a* of the base-plate, and on the side of the case O, opposite the tongue *a*, is a standard, *f*.

The slot *c* permits the case O to be adjusted slightly in any direction horizontally, and set-screws *m*, extending through the lugs *n* on the base-plate, secure the case after adjustment.

A lever, R, bearing on the standard *f*, is formed near the end into a yoke, R', inclosing the case O, and is supported at the outer end by an adjusting-bolt, S.

The sides of the case O have slots *g* to receive lugs *r* at the inside of the yoke R', the said lugs having bearings for knife-edge projections *p* on an oil-box, P, thus suspended within the case O.

An annular rib, *s*, central with the edges of the projections *p*, has a rounded outer face to permit the tilting of the oil-box in the case O, without any lateral play of the lugs *p* upon their bearings.

The oil-box has a recess at its lower end to receive a rectangular block, V, of hard metal,

rounded or pyramidal at its under side, and flat on its upper face, upon which bears the flat lower end of the shaft, the latter passing through a liner or sleeve, Q, resting with its lower end on the corners of the block V, as shown in dotted lines in Fig. 2. Ribs *v*, extending vertically outside of the block Q, coincide with ribs *u* inside the box P, leaving intermediate channels *x*, which communicate with the space W below the liner, and constitute, with said space, the oil-receptacle.

A screw-bolt, T, extending into an opening, *h*, Fig. 2, partly in the liner and partly in the oil-box, prevents the liner from turning.

The bottom end of the shaft A is hardened in any suitable manner, and having a flat bearing on the hardened block V, will revolve with but little friction and with much less wear than the ordinary shafts with rounded or pointed ends, while the block V can tilt as necessary to maintain perfect contact between the bearing faces, either of which may be channeled to permit the ready access of oil.

The central bolt U secures the base firmly without the necessity of perforating the beam at more than one point, and without interfering with the rotation of the plate to adjust the same. It also secures the plate firmly after adjustment.

By turning the plate N on the bolt U the lever R can be brought at any desired angle, horizontally, to the bridge-tree, and by moving the case O on the plate the shaft may be brought exactly to its vertical position, and, with the stone, may be elevated or lowered by adjusting the lever R, while the oil-box will swing upon its bearings to accommodate itself to any imperfection or maladjustment, thus avoiding all unequal wear of the liner, which, when worn, may readily be removed and replaced. As the liner rests only on the corners of the block V, spaces *i*, Fig. 1, are left, through which the oil may reach all the bearing parts, and all grit and sediment may pass from said parts to the chamber W to be afterward removed.

To avoid the heavy work necessary to forge the upper end of the shaft A to the proper shape, I employ a cast-metal end piece, D, terminating in a projection or cock-head, C, and

having a socket to receive the end of the shaft, which is secured by fusible metal poured between the two, the contiguous faces being grooved or recessed, to insure a firm hold upon the same; or the end piece may be shrunk on the shaft.

The cock-head C is rectangular in cross-section near the base and terminates in a conical point, *a'*, adapted to a socket in the cross-bar J of the cone-bail H.

The point *a'* and its bearing-face, or both, may be hardened or chilled in casting, so as to secure the greatest possible durability and avoid the expense of the lathe-fitting usually required.

The driver consists of a hub, G, through which extends the projection C, and from the ends of which arise two horns, F F, which extend into recesses *b'* in the cross-bar J, the hub having recesses *c'*, to receive ribs *c'* on the projection C, which ribs terminate in knife-edges on which the hub G bears, so that the driver may rock thereon slightly and thus align itself with the cross-bar J, insuring an equal bearing of the horns at all times, the ribs *c'* further strengthening the cock-head.

The bearings of the driver-horns F F, in the mortises of the cross-bar J, are on a plane or line with the point *a'* of the spindle, so that in case the spindle should be "out of tram," (as it is usually termed,) no lateral strain is thrown on the point *a'*, as would be the case were these points out of line with each other, as in the common bail and driver.

The cone-bail H is secured to the stone in the usual manner, and the grain is fed either through the same, as shown in Fig. 1, or outside the same, as shown in Figs. 5 and 6. I prefer the latter construction, as gum segments F' may then be introduced in this form of construction between the horns and cross-bar J, serving as lateral bearings for the horns and preventing the shocks or jars resulting from irregular motion of the engine.

I do not here claim the construction shown

in Figs. 5 and 6, as the same may form the subject for another application for Letters Patent; but

I claim—

1. The combination of the plate N, the case O, pivoted thereto at *b*, and adjustable thereon, and the oscillating oil-box P, supported by a lever, R, carried by the case and receiving the end of the shaft, substantially as set forth.

2. The plate N, carrying the oil-box bearing and lever R, and capable of rotation on the central bolt, U, securing the plate to the base, substantially as described.

3. The combination, with the case O, of the yoked lever R, having bearings for lugs upon an oil-box provided with a rounded-edged rib, *s*, on a plane with the edges of the lugs, substantially as and for the purpose set forth.

4. The combination, with the flat-ended shaft A, of a bearing-block, V, resting on a flat surface and having a flat upper face, and rounded upon its under face, as set forth.

5. The combination, with the oil-box P and block V, of the liner Q, bearing on the corners of the block, substantially as specified.

6. A mill-shaft consisting of a plain cylindrical bar of wrought metal and a cast-metal end piece, provided with suitable shoulders and bearing-faces and terminating in a hardened point, as set forth.

7. The combination of the cone-bail H, cross-bar J, and driver provided with upwardly-extending horns bearing laterally on the cross-bar at points opposite the bearing of the bar upon the spindle, as set forth.

In testimony whereof I have signed my name to this specification in the presence of two subscribing witnesses.

OLIVER J. BOLLINGER.

Witnesses:

F. T. SCOTT,
DAVID IRNEST.